

“Sensing the pulse of industry”

tekMass TMS Thermal Mass Multivariable Flow Sensors

The patented **tekMass TMS Series** is designed for the bi-directional mass flow measurement of single or mixed gases, where temperature and pressure are not required for compensation. **tekMass** has the largest mass and volumetric flow ranges available. These are from 0.35 kg/hr (0.8lb/hr) to over 12 million kg/hr (26million lb/hr).

tekMass uniquely embodies a high stability, two thermal sensor arrangement, either for insertion into a pipe, optionally under pressure, or as an in-line complete flow sensor. One sensor is heated and one is a reference sensor. In the reference thermal sensor, the resistance is accurately maintained constant temperature between it and the heated thermal sensor is a measurement of the mean mass flow of the gas passing the sensors.

The mass flow is affected by variation in the square root of the product of the thermal conductivity of the gas, its specific heat at constant volume, its density and its mean velocity. The latter two terms form the mass flow measurement. Therefore, the **tekMass** flow sensor is normally calibrated for the particular gas is not available for calibration, a NIST traceable air calibration is made and accurate corrections are used accounting for variation in thermal conductivity and specific heat for the particular gas type.

The **tekMass** is particularly sensitive and capable of extremely low mass velocity measurement, with a 1 second response time (0.2s time constant). It has many applications, particular in biogas measurement, compressed air, and in the power generation, chemical, steel, pulp/paper, waste, food and natural gas industries. Acetylene and other explosive gases are not approved for use.

The **tekMass TMS-S or B** are insertion devices for use in existing pipe work. It may be inserted or withdrawn into the existing pipeline, under pressure if necessary. Pipe sizes range from 10mm – 6000mm (1/2” – 240”).

The **tekMass TMS-P** is a complete in-line flow sensor, supplied with pipe spools 20 – 300mm (1/2” – 12”) diameters. In both cases no traversing is required to determine point of average velocity and no complex blockage factors need be determined.

All **tekMass** flow sensors are calibrated against a gas flow primary standard and are traceable to USA National Institute of Standards and Technology (NIST) and other international standards. Both circular and equivalent area quadrilateral duct cross sections are available. The sensor insertion rod is optionally accurately graduated and marked for the particular internal diameter in which it will be used.



tekMass TMS – P
In-Line Sensor



tekMass TMS – S or B
Insertion Sensor

tekMass TMS In-Line and Insertion Mass Flow Sensors Specification

Accuracy:	+/- 1% of reading, +/-0.5% full scale with USA NIST traceability
Resolution:	0.001 nm/s (0.0035 sfps)
Mass flow turndown:	100:1
Pipe Sizes:	10 – 6000mm (1/2" – 240") diameter or equivalent duct areas
Gas contact material:	AISI 316 stainless steel, Hastlloy C, Titanium
Mean velocity ranges:	1 – 100 nm/s (3.22 – 322 sfps)
Min volume flow rate:	min nm ³ /h = pipe ID mm ² x 0.00283 based on air at NTP min scfh = pipe ID inches ²
Min mass flow rate:	min kg/h = pipe ID mm ² x 0.00340 based on air at NTP min lb/h = pipe ID inches ² x 4.81 based on air at USA STP
Microprocessor check:	Error over calibrated range diagnosed with fault corrected reset
Media temperature ranges:	- 40° to +100° C (- 40° to + 212° F) - 40° to + 200° C (- 40° to +392° F) - 40° to + 450° C (- 40° to +842° F) - 40° to + 510° C (-40° to + 950° F)
Converter temperature:	- 40° to + 85° C (- 40° to + 113° F) no display, compact - 30° to + 70° C (- 22°F to + 158° F) with display, compact
Max pressure:	10 bar g (145 psig) standard. Special pressure to 200 bar g (2900 psig)
Max insertion pressure:	5 bar g (75 psig)

Note: Maximum pressure with a scaled insertion rod is 0.5 bar g (7.5 psig), type TMS – I

Power supply:	compact version: 24V dc/600mA or 90 – 265 Vac
Response time:	1 second (time constant 0.2s)
Pipe line materials:	carbon steel, stainless steel, PVC etc
Converter material:	stainless steel or epoxied carbon steel
Multivariable display:	7 digit LCD for instantaneous display, 8 digit for accumulated totals totalised gas mass flow, standard or normal volumetric flow, run time, accumulated run time, media temperature, standard or normal volumetric flow rate, mass flow rate
Optional outputs:	Isolated 4 – 20mA for temperature and mass flow into 1000 Ohms max RS 232 and MODBUS/RS485 photoelectric isolation, HART protocol
Relay:	2-way relay, adjustable 5A/220Vac or 5A/30Vdc
Explosive atmospheres:	Intrinsically safe to Ex ia IIC T5, flameproof proof to Ex d IIC T4
Protection:	IP65 and NEMA 4X, max humidity 90%
Vibration:	Withstands 0.25 g over 0.5 – 100 Hz, max acceleration 2.5 m/s ² (8.2 fps ²)
Seismic Resistance:	Withstands Level 9 on the MKS 64 Scale, IX on the USA Mecalli Scale. This does not include damage from direct falling or hurled debris.

tekMass TMS Flow Ranges

The following is based air at normal temperature and pressure (NPT), 20° C, 1.013 bar absolute, and USA standard temperature and pressure (STP), 60° F, 14.70 psia. The ranges are based on mean flow velocities 1 – 100 nm/s (3.5 – 350 sfps). The mass flow rate is affected by variation in the square root of the product of the thermal conductivity of the gas, its specific heat at constant volume, its density and its mean velocity.

Nominal Diameter		Air Mass Flow Range		Air Volumetric Flow Range	
mm	inches	kg / h	lb / h	nm ³ /h	scfh
10	0.50"	0.35 - 35	1.20 - 120	0.30 - 30	16 - 1600
25	1.00"	2.10 - 210	4.80 - 480	1.75 - 175	63 - 6300
32	1.25"	3.50 - 350	7.50 - 750	2.85 - 285	100 - 10000
40	1.50"	5.45 - 545	11.0 - 1100	4.50 - 450	142 - 14200
50	2.00"	8.50 - 850	19.0 - 1900	7.00 - 700	253 - 25300
65	2.50"	14.5 - 1450	30.0 - 3000	12.0 - 1200	400 - 40000
80	3"	22.0 - 2200	43.0 - 4300	18.0 - 1800	570 - 57000
100	4"	34.0 - 3400	77.0 - 7700	28.0 - 2800	1010 - 101000
125	5"	53.0 - 5300	120 - 12000	44.0 - 4400	1580 - 158000
150	6"	76.5 - 7650	170 - 17000	63.0 - 6300	2280 - 228000
200	8"	136 - 13600	300 - 30000	112 - 11200	4050 - 405000
250	10"	143 - 14300	480 - 48000	175 - 17500	6330 - 633000
300	12"	306 - 30600	700 - 70000	250 - 25000	9120 - 912000
350	14"	417 - 41700	940 - 94000	340 - 34000	12400 - 1240000
400	16"	544 - 54400	1230 - 123000	450 - 45000	16200 - 1620000
450	18"	690 - 69000	1560 - 156000	570 - 57000	20500 - 2050000
500	20"	850 - 85000	1920 - 192000	700 - 70000	25300 - 2530000
600	24"	1224 - 122400	2770 - 277000	1000 - 100000	36500 - 3650000
700	28"	1670 - 167000	3770 - 377000	1370 - 137000	50000 - 5000000
800	30"	2180 - 218000	4330 - 433000	1790 - 179000	57000 - 5700000
900	36"	2750 - 275000	6230 - 623000	2270 - 227000	82000 - 8200000
1000	40"	3400 - 340000	7700 - 770000	2800 - 280000	101000 - 10100000
1200	48"	4900 - 490000	11100 - 111000	4030 - 403000	146000 - 14600000
1400	56"	6670 - 667000	15100 - 151000	5490 - 549000	200000 - 20000000
1500	60"	7650 - 765000	17300 - 173000	6300 - 630000	228000 - 22800000
1600	64"	8700 - 870000	19700 - 197000	7170 - 717000	259000 - 25900000
1800	70"	11000 - 1100000	23600 - 2360000	9070 - 907000	310000 - 31000000
1825	72"	11320 - 1132000	25000 - 2500000	9330 - 933000	328000 - 32800000
2000	80"	13600 - 1360000	30800 - 3080000	11200 - 1120000	405000 - 40500000

tekMass TMS – I or B Insertion Type and TMS – P Sensor Straight Pipe Run Requirements

Upstream Obstruction	Min Straight Pipe Diameters Without Flow Straightener Upstream		Min Straight Pipe Diameters With Flow Straightener Upstream		Min Straight Pipe Diameters Pipe Diameters Downstream	
	TMS-S/B	TMS-P	TMS-S/B	TMS-P	TMS-S/B	TMS-P
Bend Preceded by > 9D Straight	15 D	13 D	-	5 D	5 D	4 D
Min 8° Pipe Reducer	5 D	3 D	-	5 D	5 D	4 D
2 Bends in Plane Preceded by > 9D Straight	20 D	18 D	-	10 D	5 D	4 D
2 Bends Out of Plane	25 D	23 D	-	15 D	5 D	4 D
Upstream Tee	25 D	23 D	-	15 D	5 D	4 D
Fully Open Valve	15 D	13 D	-	10 D	5 D	4 D
Throttling Control Valve	30 D	28 D	-	13 D	5 D	4 D

Note: Control valves should be downstream, with a minimum 5 D pipe length after the sensor

tekMass TMS - S Graduated Rod Insertion Type, Max Pressure 0.5 bar g (7.5 psig)

tekMass TMS – B Insertion Type, Max Pressure 10 bar g (145 psig) – No Graduations

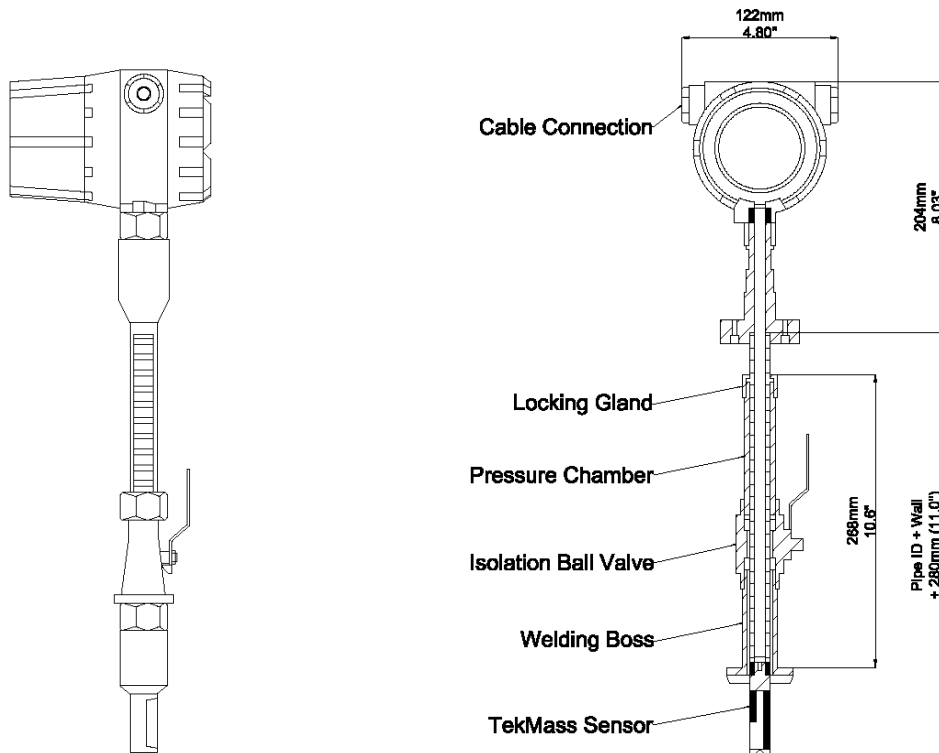

Insertion **tekMass TMS – S**

Insertion **tekMass TMS - B**

Pipe sizes: 10 – 6000 mm (1/2” – 240”) diameter

Equivalent duct diameter = $2 \sqrt{(H \times W / \pi)}$ where H = duct height, W = duct width

tekMass TMS - P In-Line Mass Flow Sensors

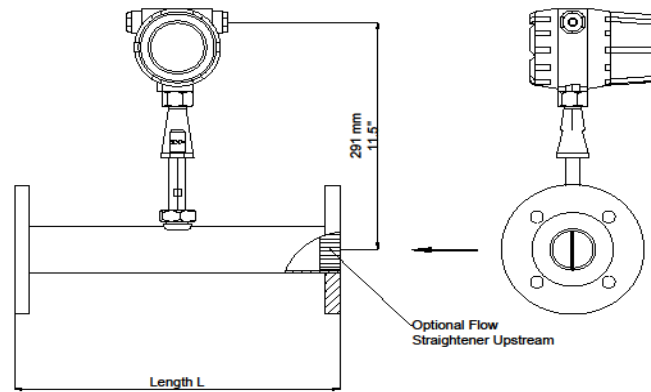

Pipe sizes: 25 – 300 mm (1" – 12") diameter

Equivalent duct diameter = $2 \sqrt{(H \times W / \pi)}$ where H = duct height, W = duct width

tekMass TMS - P In-Line Spool Piece Dimensions and Pressure Drop

Nominal Size		Length L		Pressure Drop at Maximum Standard Flow Rate			
				Without Straightener		With Straightener	
mm	inches	mm	inches	mm wg	inches wg	mm wg	inches wg
25	1.00"	280	11.0"				
32	1.25"	280	11.0"				
40	1.50"	280	11.0"	80	3"	180	7"
50	2.00"	280	11.0"				
65	2.50"	280	11.0"				
80	3"	280	11.0"				
100	4"	280	11.0"				
125	5"	290	11.4"				
150	6"	310	12.2"	50	2"	150	6"
200	8"	340	13.4"				
250	10"	370	14.6"				
300	12"	410	16.1"				

- Notes: 1) Larger sizes on request
 2) Standard maximum pressure 10 bar g (145 psig). Optional to 40 bar g (580 psig).
 Flanges to DIN PN10, JIS k10, optional DIN PN40, JIS k40, or ANSI 150 rf,
 Optional ANSI 300rf. **See Ordering Code.**
 Observe flange pressure and temperature ratings accordingly.
 3) Static pressure of gas must be > 10% higher than pressure drop at any particular
 flow rate. At half flow rate, pressure drops are 4 times less, etc, by square root law.

tekMass TMS Gas Thermal Mass Flow Sensor Ordering Code

Example :	tekMass TMS	P	0300	C	1	A	AR	2	A	3	A	2
Basic type	Insertion type with scaled insertion rod (max 0.5 barg (7.5 psig))	S										
	Insertion type- without scaled insertion rod	B										
	In-line exact pipe ID mm	P										
Exact Internal Diameter (mm) or equivalent duct size mm after code	10 mm (0.394") ID		0010									
	100 mm (3.94") ID		0100									
	300 mm (11.8") ID		0300									
	1000 mm (39.4") ID		1000									
TMS-P Process Connections	No spool piece (insertion type only) = A											
	DN PN10 = B , ANSI 150 rf = C , JIS 10K = D											
	DIN PN40 = E , ANSI 300 rf = F , JIS 40K = G											
	Other (Specify after Order Code) = H											
TMS-P Flow Straightener Option	No spool pieces (insertion type only)				1							
	Spool piece with flow straightener				2							
	Spool piece without flow straightener				3							
Gas temperature Rating	minus 40° to + 100°C (minus 40° to + 212°F)					A						
	minus 40° to + 200°C (minus 40° to + 392°F)					B						
	minus 40° to + 450°C (minus 40° to + 842°F)					C						
	minus 40° to + 510°C (minus 40° to + 960°F)					D						
Gas type	Air = AR , Natural Gas = NG , Methane = ME											
	Propane = PG , Carbon Dioxide = CD , Oxygen = OX											
	Helium = HE , Nitrogen = NI , XX = Other (State after code)											
Volumetric or Mass flow Units	kg/hr = 1 , lb/hr = 2 , nm ³ /hr = 3 , scfh = 4											
Sensor and Optional Spool Piece Material	AISI 316 stainless steel sensor and carbon steel optional spool									A		
	AISI 316 stainless steel sensor and 316 stainless steel optional spool									B		
	AISI 316 stainless steel sensor , no spool piece									C		
	Hastelloy C sensor, no spool piece									D		
	Titanium sensor , no spool piece									E		
Transmitter Output	1 x 4-20mA output for mass flow										1	
	1 x 4-20mA output for volumetric flow										2	
	2 x 4-20mA for mass flow and temperature										3	
	2 x 4-20mA for volumetric flow and temperature										4	
	The above with RS 485 / MODBUS										5	
	The above with HART										6	
Power Supply	24 Vdc										A	
	100 - 240 Vac, 50 - 60 Hz										B	
Explosive Atmosphere Options	No explosive atmosphere (Safe Area)											1
	Intrinsic safe to Ex ia IIC T3 -T5											2
	Flameproof to Ex d IIC T3 - T4											3

All flow conditions to be stated on Enquiry Form on next page



Technical Data Sheet & General Specifications

tekMass TMS Enquiry Form

Customer's Name, Project Name, & Location:						
Detail	Sensor 1	Sensor 2	Sensor 3	Sensor 4	Sensor 5	Sensor 6
Quantity						
Gas Type						
ADD any special notes, such as dirty, clean, moisture laden, mixed % concentration.						
Mass Flow Rate With Units						
Volumetric Flow Rate With Units at NTP pr STP						
Bi-directional (B)/ Uni-directional (U)						
Pressure Range and Units						
Temperature Range and Units						
Explosive Atmosphere and Type Required Intrinsicly Safe (IS) / Flameproof (FP)						
Gas Density or SG Range at NTP/STP						
Pipe Schedule or ID / Wall Thickness Specify mm or inches						
Pipe Material						
Is the flow sensor to be used in an area of magnetic fields? Yes / No						
Insertion Type With Scaled Rod (max 0.5 bar g /7.5 psig) OR:						
Insertion Type Without Scaled Rod OR						
Spool Piece type						



Factory & Flow Laboratories:
 Block 2, #04 – 685
 Balestier Road
 Singapore 320002
 Phone: + 65 (0) 67753340
 Fax: + 65 (0) 67791626

Sales and Service: sales@tekflosensors.com
 Emergency 24-Hour Service: +65 (0) 882 692 768
 Website: www.tekflosensors.com

Specifications are subject to change without notice